

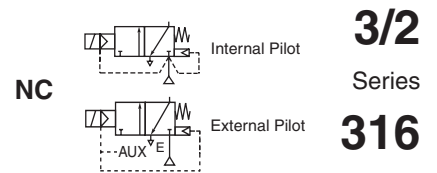

SOLENOID VALVES

pressure assisted, zero minimum, high flow
floating diaphragms
1/4 to 1/2



3/2

Series

316

FEATURES

- Brass and stainless steel bodied high flow pilot valves with two spring return floating diaphragms for larger single actuators
- Can be internally piloted, or externally piloted to convert valve to zero minimum pressure differential operation by flipping a gasket
- The internal piloting mode is default
- When externally piloted, loss of electrical power or auxiliary air exhausts air from the actuator and shifts process valve to its original position
- The solenoid valves satisfy all relevant EC Directives

Zero minimum pressure is only achieved if external pressure is applied

GENERAL

Differential pressure 0 / 1,0 - 10 bar [1 bar = 100kPa]
Response times 40 - 120 ms

fluids (*)	temperature range (TS)	seal materials (*)
air, inert gas	-20 to + 80°C (**) -20 to +120°C (**)	NBR (nitrile) FPM (fluoroelastomer)

(**) Maximum ambient temperature for low power executions is 60°C

MATERIALS IN CONTACT WITH FLUID

(*) Ensure that the compatibility of the fluids in contact with the materials is verified

	Brass body	Stainless steel body
Body	Brass	AISI 316 SS
Core tube	Stainless steel	Stainless steel
Core and plugnut	Stainless steel	Stainless steel
Core spring	Stainless steel	Stainless steel
Sealings & discs	NBR	NBR
Diaphragms	NBR	FPM
Cartridge	Welded, packless AISI 430 SS	Welded, packless AISI 430 SS
Shading coil	Copper	Silver
Rider ring	PTFE	PTFE

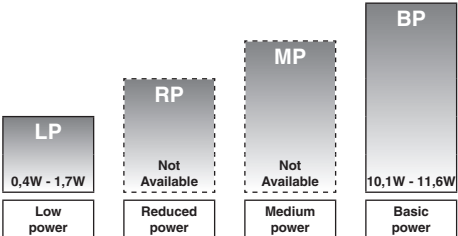
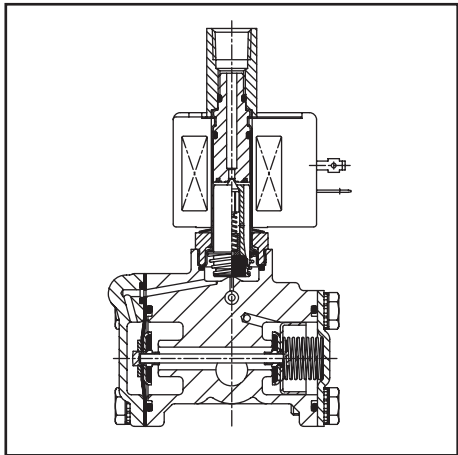
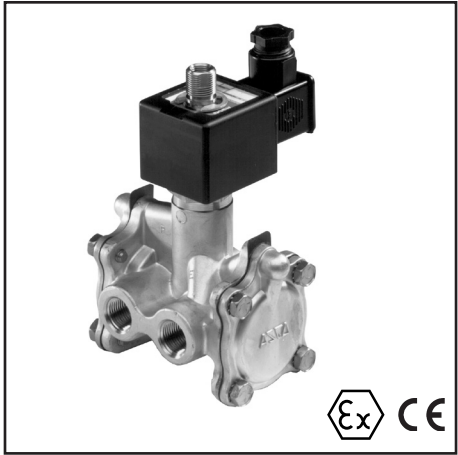

POWER LEVELS - cold electrical holding values (watt)

SPECIFICATIONS

pipe size	orifice size	flow coefficient kv		operating pressure differential (bar)			power level	prefix optional solenoids							basic catalogue number	
								max. (PS)		ATEX / IECEx						
				min.	air (*)	7 & 9		Ex d	Ex e mb	Ex mb	Ex ia	EEEx nA	brass	stainless steel		
❖	(mm)	(m³/h)	(l/min)	~	=	~/=	EF	NF	EM	PV	IS	ZN	SC			
NC - Normally closed																
1/4	8,0	1,3	21,6	0 / 1,0	10	8	BP	●	●	●	●	-	●	●	❖316A001	B316A081V
1/4	8,0	1,3	21,6	0 / 1,0	10	10	LP	○	●	●	○	○	○	●	❖316A301	B316A381V
3/8	8,0	1,5	25,7	0 / 1,0	10	8	BP	●	●	●	●	-	●	●	❖316A002	B316A082V
3/8	8,0	1,5	25,7	0 / 1,0	10	10	LP	○	●	●	○	○	○	●	❖316A302	B316A382V
3/8	16,0	3,4	56,6	0 / 1,0	10	8	BP	●	●	●	●	-	●	●	❖316A003	-
3/8	16,0	3,4	56,6	0 / 1,0	10	10	LP	○	●	●	○	○	○	●	❖316A303	-
1/2	16,0	3,4	56,6	0 / 1,0	10	8	BP	●	●	●	●	-	●	●	❖316A004	B316A084V
1/2	16,0	3,4	56,6	0 / 1,0	10	10	LP	○	●	●	○	○	○	●	❖316A304	B316A384V

- ❖ Select B for NPT ANSI 1.20.3
- Select E for ISO Rp (7/1)
- Available feature
- Available feature in DC only
- Not available

PREFIX TABLE

prefix							description	power level			
1	2	3	4	5	6	7		LP	RP	MP	BP
S	C			D	U		Dustproof (EN 50281-1-1)*	●	-	-	●
E	F						Explosionproof - NEMA 7, 9 - Zinc plated steel conduit	○	-	-	●
E	V						Explosionproof - NEMA 7, 9 - 316 SS conduit	○	-	-	●
E	M						Waterproof IP67 - Metal enclosure (EN/IEC 60079-7+18, 61241-1)*	●	-	-	●
		E	T				Threaded conduit/hole (M20 x 1,5)	●	-	-	●
I	S		S	C			Intrinsically safe with SC coil (EN/IEC 60079-11+26, 61241-11)*	○	-	-	-
N	F						Flameproof - Aluminium (EN/IEC 60079-1, 61241-1)*	●	-	-	●
P	V						Encapsulated epoxy moulded (EN/IEC 60079-18, 61241-18)*	○	-	-	●
S	C						Solenoid with spade plug connector (EN/IEC 60730)	●	-	-	●
W	P						Waterproof IP67 - Metal enclosure	●	-	-	●
W	P			D	U		Waterproof IP67 - Metal enclosure, Dustproof (EN 50281-1-1)*	●	-	-	●
W	P			I	S		I.S. with Metal IP67 enclosure (EN/IEC 60079-11+26, 61241-11)*	○	-	-	-
W	P			Z	N		Waterproof IP67 - Metal enclosure (EN 50021, 50281-1-1)*	○	-	-	●
W	S						Waterproof IP67 - 316 SS enclosure	●	-	-	-
W	S			D	U		Waterproof IP67 - 316 SS enclosure, Dustproof (EN 50281-1-1)*	●	-	-	-
W	S	E	M				Waterproof IP67 - 316 SS enclosure (EN/IEC 60079-7+18, 61241-1)*	●	-	-	●
W	S			I	S		I.S. with 316 SS IP67 enclosure (EN/IEC 60079-11+26, 61241-11)*	○	-	-	-
W	S	N	F				Flameproof - 316 SS (EN/IEC 60079-1, 61241-1)*	●	-	-	●
W	S	Z	N				Waterproof IP67 - 316 SS enclosure (EN 50021, 50281-1-1)*	○	-	-	●
						T	Threaded conduit (1/2" NPT)	●	-	-	●
						H	Class H - Battery charging circuit	-	-	-	-
						H	Class H - High temperature	-	-	-	●
Z	N					X	Moulded enclosure (EN 50021, 50281-1-1)*	○	-	-	●
							Other special constructions	-	-	-	-

SUFFIX TABLE

suffix					description	power level			
1	2	3	4	5		LP	RP	MP	BP
E					EPDM (ethylene-propylene)	●	-	-	●
J					CR (chloroprene)	●	-	-	●
N					Oxygen service (CR (chloroprene))	●	-	-	●
N	V				FPM (fluoroelastomer) and parts cleaned for oxygen service	●	-	-	●
V					FPM (fluoroelastomer)	●	-	-	●
	C	O			Epoxy coating on all external surfaces	●	-	-	●
	M	B			Mounting bracket	●	-	-	●
		P			Dry gas, non-lubricated air construction	-	-	-	-
		Q			Long life, quiet operation construction	-	-	-	○
			M	O	Push type manual operator	●	-	-	●
			M	S	Screw type manual operator	-	-	-	-
			M		Metering device	-	-	-	-

- Available feature
- Available feature in DC only
- Not available
- * ATEX solenoids are also approved according to EN 13463-1 (non electrical valves)

OPTIONS & ACCESSORIES

catalogue number	spare parts kit no. ⁽¹⁾		mounting bracket no.
	~	=	
SC ❖316A001	C318180	C318181	268975-002
SC ❖316A002	C318180	C318181	268975-002
SC ❖316A003	C318182	C318183	180748-003
SC ❖316A004	C318182	C318183	180748-003
SC B316A081	C318180	C318181	268975-002
SC B316A082	C318180	C318181	268975-002
SC B316A084	C318400	C318401	180748-003
SC ❖316A301	-	C316982	268975-002
SC ❖316A302	-	C316982	268975-002
SC ❖316A303	-	C316966	180748-003
SC ❖316A304	-	C316966	180748-003
SC B316A381	-	C316982	268975-002
SC B316A382	-	C316982	268975-002
SC B316A384	-	C318399	180748-003

- ⁽¹⁾ Standard prefixes/suffixes are also applicable to kits
❖ Select **B** for NPT ANSI 1.20.3 or select **E** for ISO Rp (7/1)
- Not available

PRODUCT SELECTION GUIDE

STEP 1

Select basic catalogue number, including pipe thread identification letter. Refer to the specifications table on page 1.

Example: E316A303

STEP 2

Select prefix (combination). Refer to the specifications table on page 1 and the prefix table on page 2, respect the indicated power level.

Example: EM

STEP 3

Select suffix (combination) if required. Refer to the suffix table on page 2, respect the indicated power level.

Example: J

STEP 4

Select voltage. Refer to standard voltages on page 3.

Example: 115V / 50Hz

STEP 5

Final catalogue / ordering number.

Example:

EM E316A303 J 115V / 50 Hz

ORDERING EXAMPLES:

WSEMT	E	316B384	240V / 60 Hz
SCHT	B	316A001 V	230V / 50 Hz
ISSC	E	316B382 MO	24V / DC
WPIS	B	316A382 MO	24V / DC
WS	E	316B384 MO	24V / DC
EM	B	316E004 E	230V / 50 Hz
PV	B	316E003 MB	230V / 50 Hz
EV	E	316G084 MB	240V / 60 Hz

prefix ⁽²⁾ pipe thread basic number ⁽²⁾ voltage suffix

ORDERING EXAMPLES KITS:

WSEM	C316966
	C318180 V ⁽³⁾
ISSC	C316982 MO
WPIS	C316982 MO

prefix basic number suffix

- ⁽²⁾ Prefix EF and EV should always be used in conjunction with change letter G in the basic number
⁽³⁾ Basic kit number applies to SC coil construction

EXPLANATION OF TEMPERATURE RANGES OF SOLENOID VALVES

Valve temperature range	The valve temperature range (TS) is determined by the selected seal material, the temperature range for proper operation of the valve and sometimes by the fluid (e.g. steam)
Operator ambient temperature range	The operator ambient temperature range is determined by the selected power level and the safety code
Total temperature range	The temperature range of the complete solenoid valve is determined by the limitations of both temperature ranges above

ELECTRICAL CHARACTERISTICS

Coil insulation class	F
Connector	Spade plug
Connector specification	ISO 4400 (cable Ø 6-10 mm)
Electrical safety	IEC 335
Standard voltages:	DC (=) 24V - 48V; Allowable voltage variation +10%, -15% AC (~) 24V - 48V - 115V - 230V/50Hz; Other voltages and 60Hz are available on request

prefix option	power ratings				operator amb. temp. range (TS) (C°) ⁽¹⁾	safety code	electrical enclosure protection (EN 60529)	replacement coil / kit		type ⁽²⁾
	inrush	holding	hot/cold	=				~	=	
	(VA)	(VA)	(W)	(W)				230 V/50 Hz	24V/DC	
Basic power (BP)										
SC	55,0	23,0	10,5	9,0/11,2	-40 to +75	EN 60730	IP65, moulded	400425-117	400425-142	01
WP/WS	55,0	23,0	10,5	9,0/11,2	-40 to +75	EN 60730	IP67, steel/SS	400405-117	400405-142	03
NF/WSNF	55,0	23,0	10,5	-	-60 to +25/40/60	II2G Ex d IIC Gb T6/T5/T4, II2D Ex t IIIC Db	IP67, alu./SS	400405-117	-	-
NF/WSNF	-	-	-	9,0/11,2	-60 to +40/60/75	II2G Ex d IIC Gb T6/T5/T4, II2D Ex t IIIC Db	IP67, alu./SS	-	400405-142	-
EM/WSEM	55,0	23,0	10,5	9,0/11,2	-40 to +40	II2G Ex e mb II T3, II2D Ex tD A21	IP67, steel/SS	400909-117	400913-142	03
PV	55,0	23,0	10,5	9,0/11,2	-40 to +65	II2G Ex mb II T3(-)/T4(=), II2D Ex mD 21	IP67, moulded	- ⁽³⁾	- ⁽³⁾	05
EF	50,0	25,0	10,1	9,0/11,6	-40 to +52/40	NEMA type 7 and 9	NEMA 4X	238614-057D	238714-006D	07
ZN	55,0	23,0	10,5	9,0/11,2	-20 to +50	II3GD EEx nA II T3	IP65, moulded	- ⁽³⁾	- ⁽³⁾	01
WPZN/WSZN	55,0	23,0	10,5	9,0/11,2	-40 to +75	II3GD EEx nA II T3	IP67, steel/SS	400405-117	400405-142	03/04
Low power (LP)										
SC	1,5	1,5	1,5	1,7/1,7	-40 to +60	EN 60730	IP65, moulded	400925-097	400925-042	02
WP/WS	1,5	1,5	1,5	1,7/1,7	-40 to +60	EN 60730	IP67, steel/SS	400926-097	400926-042	04
NF/WSNF	1,85	1,85	1,85	1,5/1,8	-60 to +55	II2G Ex d IIC Gb T6, II2D Ex t IIIC Db	IP67, alu./SS	- ⁽⁴⁾	400914-542	-
EM/WSEM	1,5	1,5	1,5	1,7/1,7	-40 to +40/55	II2G Ex e mb II T6/T5, II2D Ex tD A21	IP67, steel/SS	400926-097	400926-042	04
PV	-	-	-	1,7/1,7	-40 to +60	II2G Ex mb II T6, II2D Ex mD 21	IP67, moulded	-	- ⁽³⁾	06
EF	-	-	-	1,4/1,4	-40 to +60	NEMA type 7 and 9	NEMA 4X	-	238714-902D	08
ISSC	-	-	-	0,4/0,4	-40 to +60	II2G Ex ia IIC T6, II2D Ex iaD 21	IP65, moulded	-	268976-001	09
WPIS/WSIS	-	-	-	0,4/0,4	-40 to +60	II2G Ex ia IIC T6, II2D Ex iaD 21	IP67, steel/SS	-	268900-001	04
ZN	-	-	-	1,7/1,7	-20 to +50	II3GD EEx nA II T3	IP65, moulded	-	- ⁽³⁾	02
WPZN/WSZN	1,5	1,5	1,5	1,7/1,7	-40 to +60	II3GD EEx nA II T6	IP67, steel/SS	400926-097	400926-042	04

⁽¹⁾ Temperature range can be limited by sealings

⁽³⁾ Multiple coil kits are available under ATEX/IECEx, contact us

- Not available

⁽²⁾ Refer to the dimensional drawings on page 4 and 5

⁽⁴⁾ AC (-) limited to 127V/50/60Hz or 125V/DC

ADDITIONAL OPTIONS

- Other pipe threads are available on request
- Ex mb (prefix "PV") execution can be supplied in various cable lengths
- Compliance with "UL", "CSA" and other local approvals available on request
- 1/2" NPT (prefix "T") and M20 x 1,5 (prefix "ET") conduits (aluminium or 316 SS) available for steel solenoid housing
- Special moulded-in solid state components for peak voltage suppression and/or rectification (four diode bridge)

INSTALLATION

- Multi language installation/maintenance instructions are included with each valve
- The solenoid valves can be mounted in any position without affecting operation
- Threaded pipe connection identifier is B = NPT (ANSI 1.20.3); E = ISO-7
- Important: a minimum operating pressure differential must be maintained between the pressure and exhaust ports. Supply and exhaust piping must be full area and unrestricted
- Declarations of conformity are available on request
- Ex e mb (prefix "EM") execution: solenoid enclosure has a cable gland with integral strain relief for cables with an o.d. from 7 to 12 mm and is provided with an internal and external connection facility for an earthing or bonding conductor

DIMENSIONS (mm), WEIGHT (kg)



TYPE 01
Epoxy moulded
SC: IEC 335 / ISO 4400
ZN: EN 50021

316A001 / A002 / A003 / A004 / A081 / A082 / A084

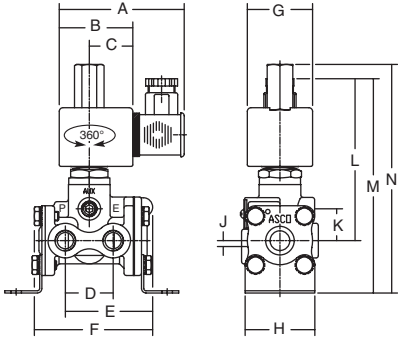

TYPE 02
Epoxy moulded
SC: IEC 335 / ISO 4400
ZN: EN 50021

316A301 / A302 / A303 / A304 / A381 / A382 / A384

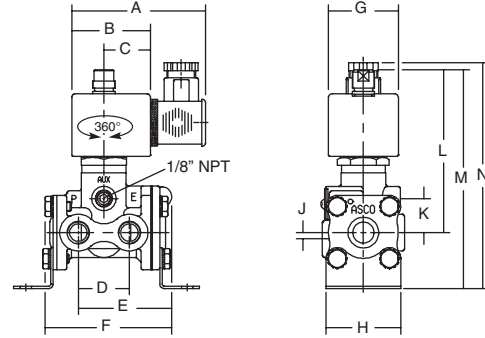

TYPE 03
Metal, epoxy coated / AISI 316 SS
WP / WS: IEC 335
EM / WSEM: EN 60079-7/18 and EN 61241-1
WPZN / WSZN: EN-50021, 50281-1-1

316A001 / A002 / A003 / A004 / A081 / A082 / A084

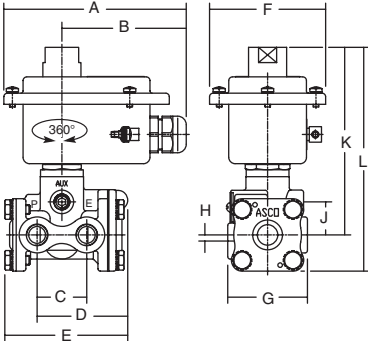

TYPE 04
Metal, epoxy coated / AISI 316 SS
WP / WS: IEC 335
EM / WSEM: EN 60079-7/18 and EN 61241-1
WPZN / WSZN: EN-50021, 50281-1-1
WPIS / WSIS: EN/IEC 60079-11+26 / 61241-11

316A301 / A302 / A303 / A304 / A381 / A382 / A384

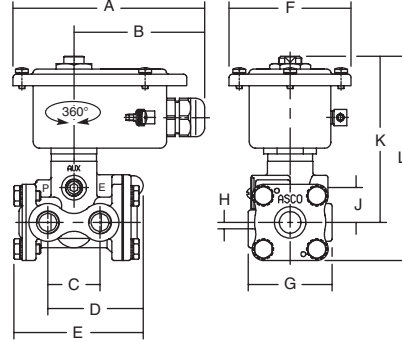

TYPE 05
Epoxy encapsulated
PV: EN/IEC 60079-18 and EN/IEC 61241-18

316A001 / A002 / A003 / A004 / A081 / A082 / A084

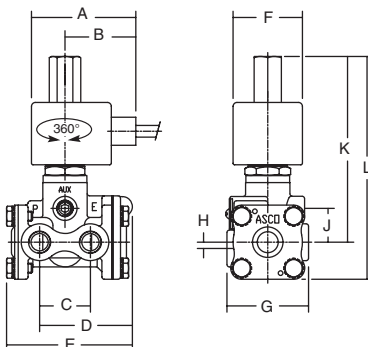

TYPE 06
Epoxy encapsulated
PV: EN/IEC 60079-18 and EN/IEC 61241-18

316A301 / A302 / A303 / A304 / A381 / A382 / A384

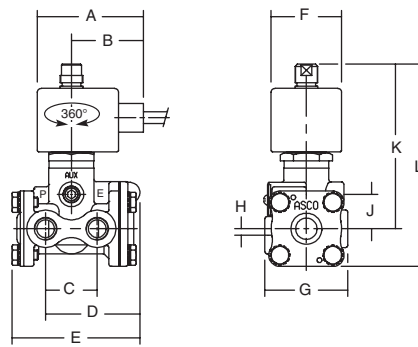

DIMENSIONS (mm), WEIGHT (kg)

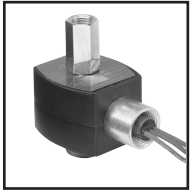

TYPE 07
Epoxy encapsulated
EF: ICS-6 ANSI / NEMA Type 7 and 9
NOTE: applicable to solenoid only

316G001 / G002 / G003 / G004 / G081 / G082 / G084

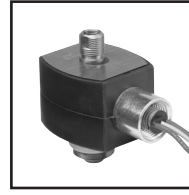
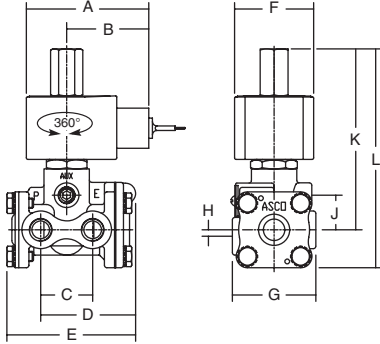

TYPE 08
Epoxy encapsulated
EF: ICS-6 ANSI / NEMA Type 7 and 9
NOTE: applicable to solenoid only

316G301 / G302 / G303 / G304 / G381 / G382 / G384

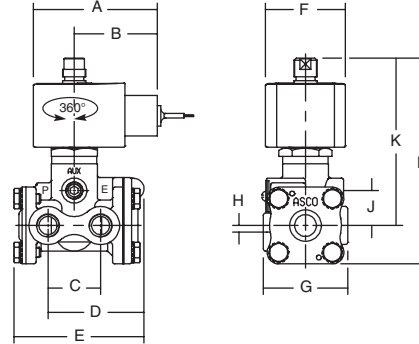

TYPE 09
PP moulded
ISSC: EN/IEC 60079-11+26 / 61241-11

316A301 / A302 / A303 / A304 / A381 / A382 / A384

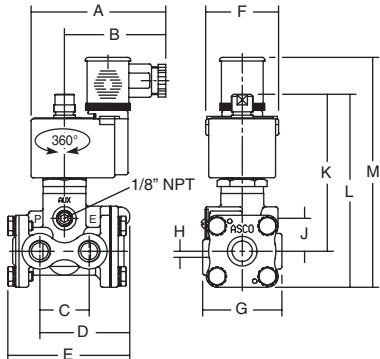

type	prefix option	power level	A	B	C	D	E	F	G	H	J	K	L	M	N	weight
01	SC, ZN	BP	85	50	30	33	81	81	45	48	4	22	110	147	156	2,50 kg
02	SC, ZN	LP	85	50	30	33	60	81	45	48	4	22	104	140	144	2,50 kg
03	WP, WS, EM, WSEM, WPZN, WSNZ	BP	120	82	33	60	76	76	52	4	22	123	147	-	-	2,60 kg
04	WP, WS, EM, WSEM, WPZN, WSNZ	LP	120	82	33	60	77	77	52	4	22	104	128	-	-	2,60 kg
04	WPIS, WSIS	LP	120	82	33	60	77	77	52	4	22	104	128	-	-	2,60 kg
05	PV	BP	67	45	33	66	87	45	52	4	22	119	143	-	-	2,50 kg
06	PV	LP	67	45	33	60	45	45	52	4	22	104	128	-	-	2,50 kg
07	EF	BP	77	51	33	60	50	50	52	4	22	113	137	-	-	2,50 kg
08	EF	LP	77	52	33	60	50	50	52	4	22	104	128	-	-	2,50 kg
09	ISSC	LP	89	67	33	60	48	48	52	4	22	104	128	152	-	2,60 kg

SECTIONAL DRAWING

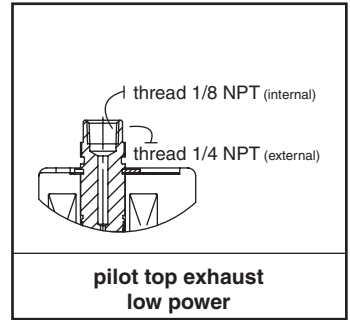
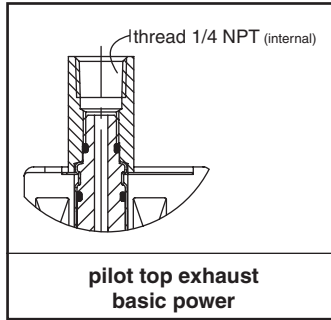
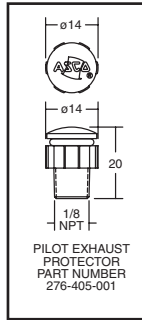
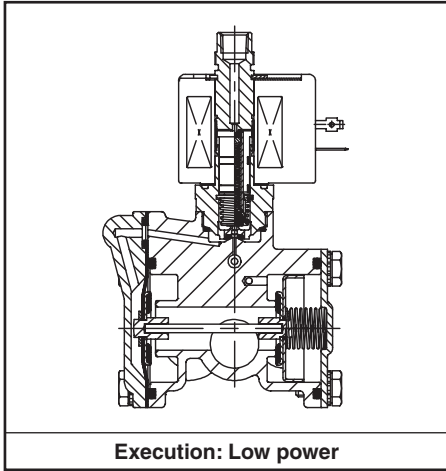

MOUNTING BRACKETS

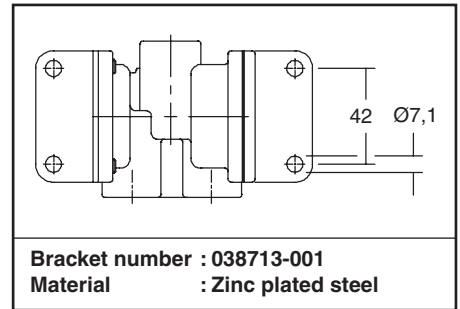
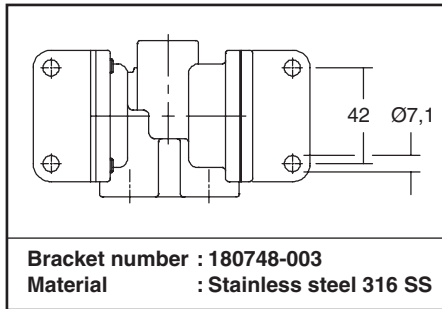
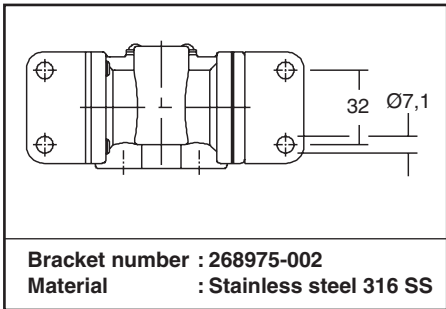

Internal Piloting

"EXT" mark is covered

"INT" marking shown. This indicates correct assembly for internal piloting

External Piloting

"INT" mark is covered

"EXT" marking shown. This indicates correct assembly for external piloting

large and small flow gaskets shown in support

