

FEATURES

- The valves are certified according to IEC 61508 Functional Safety data and have SIL-4 capability (TÜV approval) and SIL-3 capability (Exida approval)
- The solenoid valves are recommended for pilot applications with basic flow, wide pressure ranges and no minimum operating pressure
- PTFE rider rings and graphite-filled PTFE seals reduce friction and eliminate sticking
- Coils used in metal enclosures have class H insulation materials
- Special execution for low power
- Special execution for extreme low ambient temperatures
- Peak voltage suppression diodes are standard in DC solenoids with metal enclosures
- The solenoid valves satisfy all relevant EC Directives

GENERAL

Differential pressure	0 - 10 bar [1 bar = 100kPa]
Maximum viscosity	65cST (mm ² /s)
Response times	75 - 100 ms

fluids (*)	temperature range (TS)	seal materials (*)
air, inert gas, water, oil	-20 to +120°C	FPM (fluoroelastomer)
	-40 to + 40°C	VMQ (silicone)
	-50 to + 60°C	(F)VMQ ((fluoro)silicone)

MATERIALS IN CONTACT WITH FLUID

(*) Ensure that the compatibility of the fluids in contact with the materials is verified

	Brass body	Stainless steel body
Body	Brass	AISI 316L SS
Stem	Stainless steel	Stainless steel
Core tube	Stainless steel	Stainless steel
Core and plugnut	Stainless steel	Stainless steel
Springs	Stainless steel	Stainless steel
Sealings & poppets	FPM, VMQ or (F)VMQ	FPM, VMQ or (F)VMQ
Rider ring	PTFE	PTFE

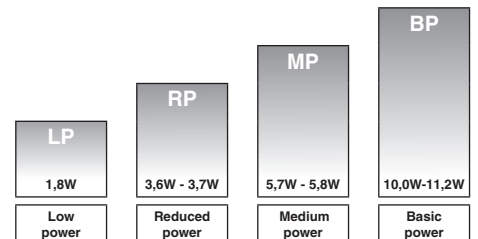
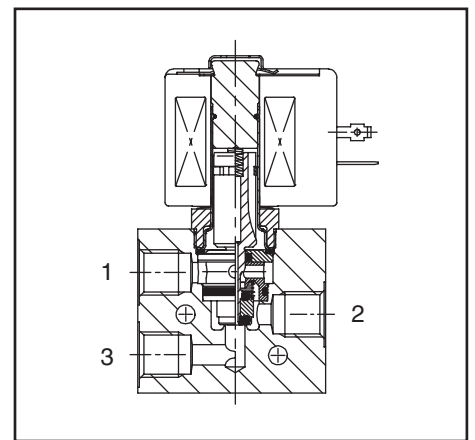

POWER LEVELS - cold electrical holding values (watt)

SPECIFICATIONS

pipe size	orifice size	flow coefficient Kv		operating pressure differential (bar)		power level	prefix optional solenoids						basic catalogue number			
							min.	max. (PS)	NEMA 7&9	ATEX / IECEx					IP65	
										air/water (*)	Ex d	Ex e mb				Ex mb
❖	(mm)	(m ³ /h)	(l/m)			~/=	~/=	EF	NF	EM	PV	ZN	SC	brass	stainless st.	
U - Universal, FPM sealings and poppets																
1/4	5,7	0,45	7,5	0	10	BP	●	●	●	○	○	●	❖ 327B001	❖ 327B002		
1/4	5,7	0,45	7,5	0	10	MP	-	●	●	-	○	●	❖ 327B201	❖ 327B202		
1/4	5,7	0,45	7,5	0	10	RP	-	●	●	-	○	●	❖ 327B101	❖ 327B102		
1/4	5,7	0,45	7,5	0	10	LP	-	●	-	-	-	-	❖ 327B301	❖ 327B302		
U - Universal, VMQ sealings and poppets																
1/4	5,7	0,45	7,5	0	10	BP	●	●	●	○	○	●	❖ 327B011	❖ 327B012		
U - Universal, (F)VMQ sealings and poppets																
1/4	5,7	0,45	7,5	0	10	MP	-	●	●	-	○	●	❖ 327B211	❖ 327B212		
1/4	5,7	0,45	7,5	0	10	RP	-	●	●	-	○	●	❖ 327B111	❖ 327B112		
1/4	5,7	0,45	7,5	0	10	LP	-	●	-	-	-	-	❖ 327B311	❖ 327B312		

❖ Select 8 for NPT ANSI 1.20.3 or Select G for ISO G(228/1)

● Available feature

○ Available feature in DC only

- Not available

PREFIX TABLE

prefix							description	power level			
1	2	3	4	5	6	7		LP	RP	MP	BP
S	C			D	U		Dustproof (EN 50281-1-1)*	-	●	●	●
E	F						Explosionproof - NEMA 7, 9 - Zinc plated steel conduit	-	-	-	●
E	V						Explosionproof - NEMA 7, 9 - 316 SS conduit	-	-	-	●
E	M						Waterproof IP67 - Metal enclosure (EN/IEC 60079-7+18, 61241-1)*	-	●	●	●
		E	T				Threaded conduit/hole (M20 x 1,5)	-	●	●	●
I	S			S	C		Intrinsically safe with SC coil (EN/IEC 60079-11+26, 61241-11)*	-	-	-	-
N	F						Flameproof - Aluminium (EN/IEC 60079-1, 61241-1)*	●	●	●	●
P	V						Encapsulated epoxy moulded (EN/IEC 60079-18, 61241-18)*	-	-	-	○
S	C						Solenoid with spade plug connector (EN/IEC 60730)	-	●	●	●
W	P						Waterproof IP67 - Metal enclosure	-	●	●	●
W	P			D	U		Waterproof IP67 - Metal enclosure, Dustproof (EN 50281-1-1)*	-	●	●	●
W	P			I	S		I.S. with Metal IP67 enclosure (EN/IEC 60079-11+26, 61241-11)*	-	-	-	-
W	P			Z	N		Waterproof IP67 - Metal enclosure (EN 50021, 50281-1-1)*	-	●	●	●
W	S						Waterproof IP67 - 316 SS enclosure	-	●	●	●
W	S			D	U		Waterproof IP67 - 316 SS enclosure, Dustproof (EN 50281-1-1)*	-	●	●	●
W	S	E	M				Waterproof IP67 - 316 SS enclosure (EN/IEC 60079-7+18, 61241-1)*	-	●	●	●
W	S			I	S		I.S. with 316 SS IP67 enclosure (EN/IEC 60079-11+26, 61241-11)*	-	-	-	-
W	S	N	F				Flameproof - 316 SS (EN/IEC 60079-1, 61241-1)*	●	●	●	●
W	S	Z	N				Waterproof IP67 - 316 SS enclosure (EN 50021, 50281-1-1)*	-	●	●	●
							Threaded conduit (1/2" NPT)	-	-	●	●
					H	C	Class H - Battery charging circuit	-	●	-	●
					H	T	Class H - High temperature	-	-	-	-
Z	N						Moulded enclosure (EN 50021, 50281-1-1)*	-	○	○	○
						X	Other special constructions	-	●	●	●

PRODUCT SELECTION GUIDE

STEP 1

Select basic catalogue number, including pipe thread identification letter. Refer to the specifications table on page 1.

Example: 8327B001

STEP 2

Select prefix (combination). Refer to the specifications table on page 1 and the prefix table on page 2, respect the indicated power level.

Example: NF

STEP 3

Select suffix (combination) if required. Refer to the suffix table on page 2, respect the indicated power level.

Example: MS

STEP 4

Select voltage. Refer to standard voltages on page 3.

Example: 230V / 50/60Hz

STEP 5

Final catalogue / ordering number.

Example:

NF 8327B001 MS 230V / 50/60 Hz

SUFFIX TABLE

suffix					description	power level			
1	2	3	4	5		LP	RP	MP	BP
E					EPDM (ethylene-propylene)	-	-	-	-
J					CR (chloroprene)	-	-	-	-
N					Oxygen service (CR (chloroprene))	-	-	-	-
N	V				FPM (fluoroelastomer) and parts cleaned for oxygen service	●	●	●	●
	C	O			Epoxy coating on all external surfaces	●	●	●	●
	M	B			Mounting bracket	-	-	-	-
			M	O	Push type manual operator	●	●	●	●
			M	S	Screw type manual operator ⁽¹⁾	●	●	●	●
				M	Metering device	-	-	-	-

● Available feature

○ Available feature in DC only

- Not available

* ATEX solenoids are also approved according to EN 13463-1 (non electrical valves)

⁽¹⁾ Functional Safety certification is not applicable with this feature

OPTIONS & ACCESSORIES

catalogue number	spare part kit no. ⁽²⁾	mounting bracket
	~ / =	
SC ❖327B001	C123670	■
SC ❖327B002	C123670	■
SC ❖327B011	C131237	■
SC ❖327B012	C131237	■
SC ❖327B101	C132251	■
SC ❖327B102	C132251	■
SC ❖327B111	C132253	■
SC ❖327B112	C132253	■
SC ❖327B201	C132251	■
SC ❖327B202	C132251	■
SC ❖327B211	C132253	■
SC ❖327B212	C132253	■
SC ❖327B301	C133441	■
SC ❖327B302	C133441	■
SC ❖327B311	C133442	■
SC ❖327B312	C133442	■

❖ Select 8 for NPT ANSI 1.20.3 or select G for ISO G(228/1)

⁽²⁾ Standard prefixes/suffixes are also applicable to kits

■ Mounting holes in body

ORDERING EXAMPLES VALVES:

SC	8	327B001	24V / DC
WSEMT	G	327B002	MS 24V / DC
NFET	G	327B001	230V / 50/60 Hz
WSEM	G	327B002	MS 24V / DC
NF	8	327B211	24V / DC
WS	G	327B001	MS 24V / DC
EM	8	327B201	230V / 50/60 Hz
PV	8	327B012	MS 24V / DC
EF	G	327H002	MS 240V / 50/60 Hz

prefix ⁽³⁾ pipe thread basic number ⁽³⁾ voltage suffix

ORDERING EXAMPLES KITS:

	C131237 ⁽⁴⁾	
WSEM	C123670	MS
NF	C131237	
WSEM	C123670	MO

prefix basic number suffix

⁽³⁾ Prefix EF and EV should always be used in conjunction with change letter H in the basic number

⁽⁴⁾ Basic kit number applies to SC coil construction

EXPLANATION OF TEMPERATURE RANGES OF SOLENOID VALVES

Valve temperature range	The valve temperature range (TS) is determined by the selected seal material, the temperature range for proper operation of the valve and sometimes by the fluid (e.g. steam)
Operator ambient temperature range	The operator ambient temperature range is determined by the selected power level and the safety code
Total temperature range	The temperature range of the complete solenoid valve is determined by the limitations of both temperature ranges above

ELECTRICAL CHARACTERISTICS

Coil insulation class	H
Electrical safety	IEC 335
Standard voltages	DC (=) 24V - 48V; Allowable voltage variation ± 10%
	AC (~) 24V - 48V - 115V - 230V/50/60Hz; Other voltages are available on request

prefix option	power ratings				operator ambient temperature range (C°) ⁽¹⁾	safety code	electrical enclosure protection (EN 60529)	replacement coil / kit		type ⁽²⁾
	inrush	holding	hot/cold	=				~	=	
	(VA)	(VA)	(W)	(W)				230V/50/60 Hz	24V/DC	
Basic power (BP)										
SC	10,0	10,0	10,0	9,0/11,2	-40 to +55	EN 60730	IP65, moulded	123664-017	400425-142	01
SCDU	10,0	10,0	10,0	9,0/11,2	-40 to +50/55	II3D T100°C/T135°C	IP65, moulded	- ⁽³⁾	- ⁽³⁾	01
WP/WS	10,0	10,0	10,0	9,0/11,2	-40 to +55	EN 60730	IP67, steel /SS	400915-017	400913-142	03
WPDU/WSDU	10,0	10,0	10,0	9,0/11,2	-40 to +55	II3D T135°C	IP67, steel /SS	400915-017	400913-142	03
NF/WSNF	10,0	10,0	10,0	9,0/11,2	-60 to +40/60	II2G Ex d IIC Gb T6/T5, II2D Ex t IIIC Db	IP67, alu./SS	400915-017	400913-142	05
EM/WSEM	10,0	10,0	10,0	9,0/11,2	-40 to +40	II2G Ex e mb II T3, II2D Ex tD A21	IP67, steel /SS	400915-017	400913-142	03
PV	-	-	-	9,0/11,2	-40 to +55	II2G Ex mb II T4, II2D Ex mD 21	IP67, moulded	-	- ⁽³⁾	06
EF/EV	12,0	12,0	12,0	9,3/11,6	-40 to +52/40	NEMA type 7 and 9	NEMA 4X	276002-058D	238714-006D	07
ZN	-	-	-	9,0/11,2	-20 to +50	II3GD EEx nA II T3	IP65, moulded	-	- ⁽³⁾	01
WPZN/WSZN	10,0	10,0	10,0	9,0/11,2	-40 to +55	II3GD EEx nA II T4/T3(=)	IP67, steel /SS	400915-017	400913-142	03
Medium Power (MP)										
SC	5,8	5,8	5,8	5,2/5,7	-40 to +90	EN 60730	IP65, moulded	400924-297	400923-442	02
SCDU	5,8	5,8	5,8	5,2/5,7	-40 to +50/75	II3D T100°C/T135°C	IP65, moulded	- ⁽³⁾	- ⁽³⁾	02
WP/WS	5,8	5,8	5,8	5,2/5,7	-40 to +90	EN 60730	IP67, steel /SS	400921-297	400914-442	04
WPDU/WSDU	5,8	5,8	5,8	5,2/5,7	-40 to +90	II3D T135°C	IP67, steel /SS	400921-297	400914-442	04
NF/WSNF	5,8	5,8	5,8	5,2/5,7	-60 to +60/75/90	II2G Ex d IIC Gb T6/T5/T4, II2D Ex t IIIC Db	IP67, alu./SS	400921-297	400914-442	05
EM/WSEM	5,8	5,8	5,8	5,2/5,7	-40 to +40/75/90	II2G Ex e mb II T5/T4/T3, II2D Ex tD A21	IP67, steel /SS	400921-297	400914-442	04
ZN	-	-	-	5,2/5,7	-20 to +50	II3GD EEx nA II T3	IP65, moulded	-	- ⁽³⁾	02
WPZN/WSZN	5,8	5,8	5,8	5,2/5,7	-40 to +40/60/90	II3GD EEx nA II T6/T5/T4	IP67, steel /SS	400921-297	400914-442	04
Reduced Power (RP)⁽⁴⁾										
SC	3,7	3,7	3,7	3,2/3,6	-40 to +55	EN 60730	IP65, moulded	- ⁽⁴⁾	400923-042	02
SCDU	3,7	3,7	3,7	3,2/3,6	-40 to +50/55	II3D T100°C/T135°C	IP65, moulded	- ⁽⁴⁾	- ⁽³⁾	02
WP/WS	3,7	3,7	3,7	3,2/3,6	-40 to +55	EN 60730	IP67, steel /SS	- ⁽⁴⁾	400914-242	04
WPDU/WSDU	3,7	3,7	3,7	3,2/3,6	-40 to +55	II3D T135°C	IP67, steel /SS	- ⁽⁴⁾	400911-242	04
NF/WSNF	3,7	3,7	3,7	3,2/3,6	-60 to +60	II2G Ex d IIC Gb T6, II2D Ex t IIIC Db	IP67, alu./SS	- ⁽⁴⁾	400914-242	05
EM/WSEM	3,7	3,7	3,7	3,2/3,6	-40 to +40/55	II2G Ex e mb II T6/T5, II2D Ex tD A21	IP67, steel /SS	- ⁽⁴⁾	400914-242	04
ZN	-	-	-	3,2/3,6	-20 to +50	II3GD EEx nA II T3	IP65, moulded	-	- ⁽³⁾	02
WPZN/WSZN	3,7	3,7	3,7	3,2/3,6	-40 to +55	II3GD EEx nA II T6	IP67, steel /SS	- ⁽⁴⁾	400914-242	04
Low Power (LP)⁽⁴⁾										
NF/WSNF	1,85	1,85	1,85	1,5/1,8	-60 to +55	II2G Ex d IIC Gb T6, II2D Ex t IIIC Db	IP67, alu./SS	- ⁽⁴⁾	400914-542	05

⁽¹⁾ Temperature range can be limited by sealings ⁽²⁾ Refer to the dimensional drawings on page 4 and 5 ⁽³⁾ Multiple coil kits are available under ATEX/IECEx, contact us
⁽⁴⁾ AC (~) limited to 127V/50/60Hz or 125V/DC - Not available

ELECTRICAL CONNECTIONS

prefix	connection
SC, SCDU, ZN	Spade plug connector with cable gland EN175301-803A (ISO 4400) for cables with an outer diameter from 6 to 10 mm
WP, WS, EM, WSEM, WPZN, WSZN, WPDU, WSDU	M20 cable gland for cables with an outer diameter from 7 to 12 mm. With an internal and external facility for an earthing or bonding conductor
NF, WSNF	1/2" NPT threaded cable entry. Enclosures are supplied without cable gland
NFET, WSNFET	M20 x 1,5 threaded cable entry. Enclosures are supplied without cable gland

ADDITIONAL OPTIONS

- Ex mb/mD (prefix "PV") solenoid can be supplied with various cable lengths
- Compliance with "UL", "CSA" and other local approvals available on request

INSTALLATION

- Multi language installation/maintenance instructions are included with each valve
- The solenoid valves can be mounted in any position without affecting operation
- The mounting holes are provided in the valve body
- Threaded pipe connection identifier is 8 = NPT (ANSI 1.20.3); G = G (ISO 228/1)
- Declarations of conformity are available on request
- Ex e mb Prefix "EM" execution: solenoid enclosure has a cable gland with integral strain relief for cables with an o.d. from 7 to 12 mm and is provided with an internal and external connection facility for an earthing or bonding conductor
- Ex d Prefix "NF/WSNF" enclosure is provided with a 1/2" NPT threaded entry hole, M20 x 1,5 (prefix "ET") is optional Both are supplied without cable gland
- All DC solenoids with metal enclosure are provided with switch-off peak voltage suppression diodes
- To comply with IEC 61508 (SIL) the valves must be provided with a specific exhaust protector (as shown on page 6) or equal

DIMENSIONS (mm), WEIGHT (kg)



TYPE 01:
Epoxy moulded
SC: IEC 335 / ISO 4400
SCDU: EN 50281-1-1
ZN: EN 50021, 50281-1-1

327B001 / B002 / B011 / B012

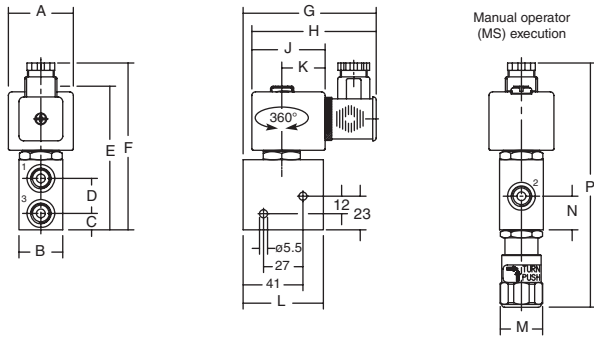

TYPE 02:
Epoxy moulded
SC: IEC 335 / ISO 4400
SCDU: EN 50281-1-1
ZN: EN 50021, 50281-1-1

327B101 / B102 / B111 / B112 / B201 / B202 / B211 / B212

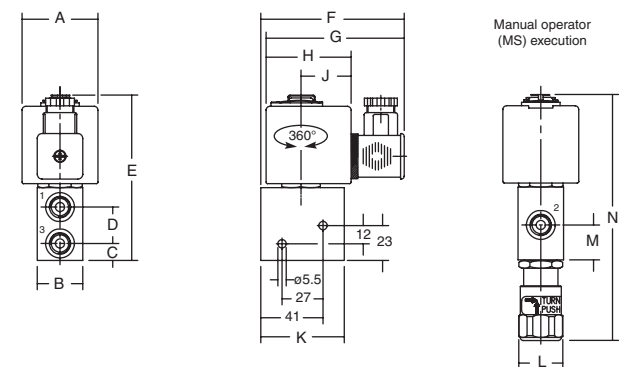

TYPE 03:
Metal, epoxy coated / AISI 316 SS
WP / WS: IEC 335
EM / WSEM: EN/IEC 60079-7+18, 61241-1
WPZN / WSNZ: EN 50021, 50281-1-1
WPDU / WSDU: EN 50281-1-1

327B001 / B002 / B011 / B012

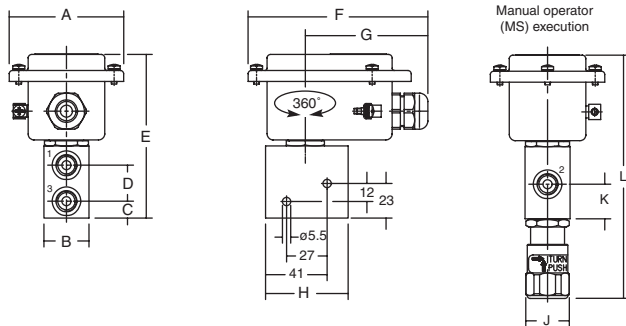

TYPE 04:
Metal, epoxy coated / AISI 316 SS
WP / WS: IEC 335
EM / WSEM: EN/IEC 60079-7+18, 61241-1
WPZN / WSNZ: EN 50021, 50281-1-1
WPDU / WSDU: EN 50281-1-1

327B101 / B102 / B111 / B112 / B201 / B202 / B211 / B212

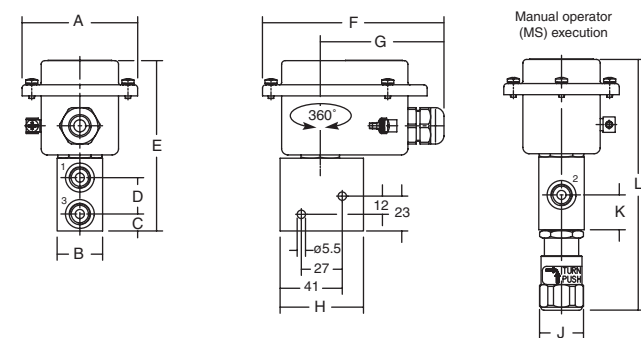

DIMENSIONS (mm), WEIGHT (kg)



TYPE 05:
Aluminium, epoxy coated / AISI 316 SS
NF/WSNF: EN/IEC 60079-1, 61241-1

327B001 / B002 / B011 / B012 / B101 / B102 / B111 / B112 /
327B201 / B202 / B211 / B212 / B301 / B302 / B311 / B312



TYPE 06:
Epoxy encapsulated
PV: EN/IEC 60079-18, 61241-18

327B001 / B002 / B011 / B012

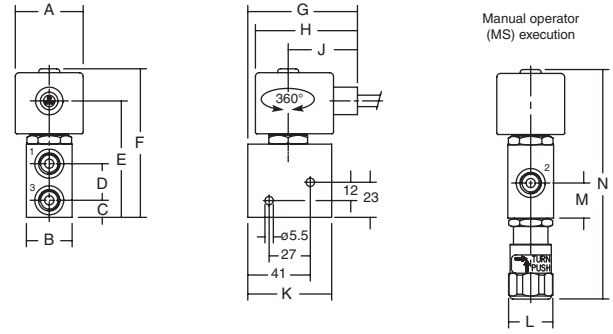
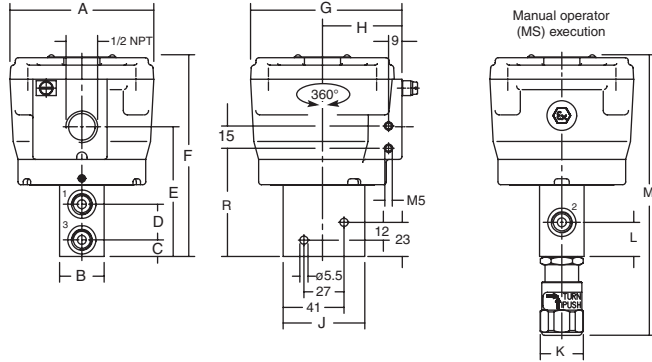

TYPE 07:
Epoxy encapsulated
EF and EV: NEMA type 7, 9 / ICS-6 ANSI

327H001 / H002 / H011 / H012

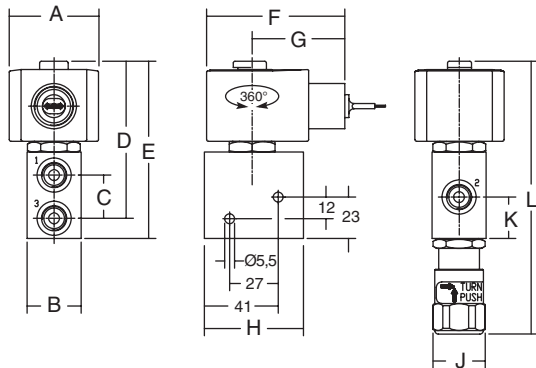

type	prefix/option	power level	A	B	C	D	E	F	G	H	J	K	L	M	N	P	R	weight
01	SC, SCDU, ZN	BP	45	30	11	24	90	114	91	85	50	30	55	29	23	167	-	0,95 kg
02	SC, SCDU, ZN	MP/RP	50	30	11	24	109	95	87	56	53	55	29	23	162	-	-	1,05 kg
03	WP, WS, EM, WSEM, WPZN, WSNZ	BP	77	30	11	24	109	120	81	55	29	23	162	-	-	-	-	1,00 kg
04	WP, WS, EM, WSEM, WPZN, WSNZ, WPDU, WSDU	MP/RP	77	30	11	24	112	120	81	55	29	23	165	-	-	-	-	1,00 kg
05	NF, WSNF	BP/MP/RP	97	30	11	24	87	136	102	54	55	29	23	189	-	-	73	2,60 kg
05	NF, WSNF	LP	97	30	11	24	97	146	102	54	55	29	23	199	-	-	83	2,65 kg
06	PV	BP	45	30	11	24	76	97	72	67	45	55	29	23	150	-	-	1,05 kg
07	EF, EV	BP	50	30	24	87	98	77	51	55	29	23	151	-	-	-	-	0,95 kg

DIMENSIONS (mm), WEIGHT (kg)



SECTIONAL DRAWING

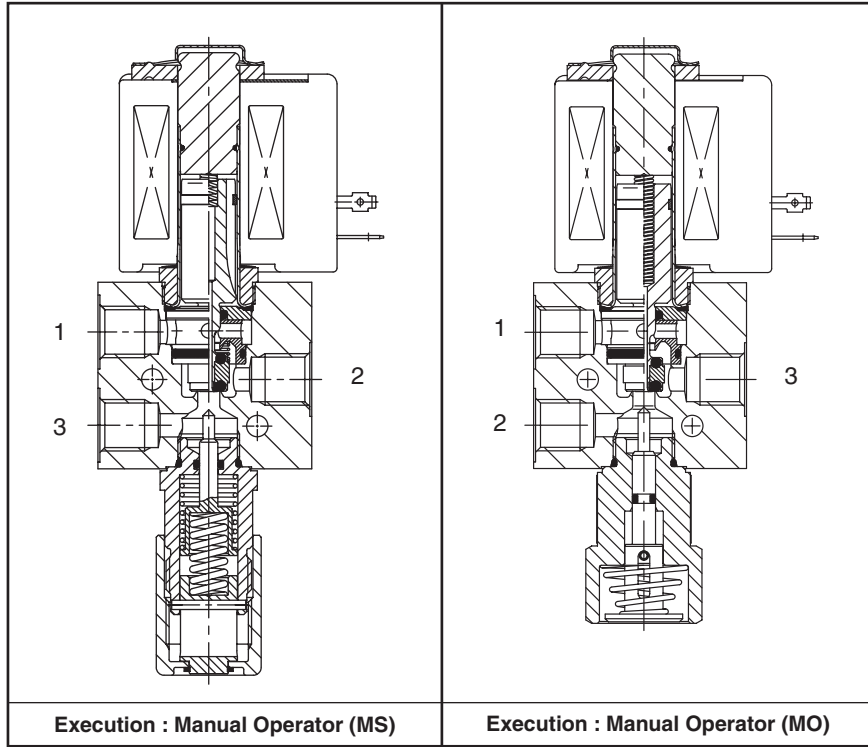

EXHAUST PROTECTOR

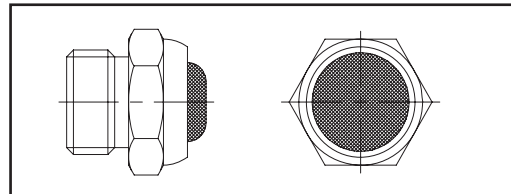

EXHAUST PROTECTOR ORDER NUMBERS

1/4	ISO 228/1	brass/nickel	B-MV110014
	NPT		B-PV110014
	ISO 228/1	stainless steel	B-VX110014
	NPT		B-PV110014 Inox