

FEATURES

- Lever type Manual Reset function which means that the valve has to be energized as well as manually operated before it stays in the "latched" position
- The No Voltage Release (NVR) function will make sure that the valve trips when de-energized
- The solenoid valves are recommended for 3/2 way pilot applications with full flow and wide pressure ranges
- Stainless steel or brass bodied valves with stainless steel internal parts
- The use of first class materials and thorough valves testing ensure a high reliability and a long service life
- The solenoid valves satisfy all relevant EC Directives

GENERAL

Differential pressure 0 - 10 bar [1 bar = 100kPa]
Maximum viscosity 65cST (mm²/s)
Response times 75 - 100 ms

fluids (*)	temperature range (TS)	seal material (*)
air, inert gas	- 40°C to + 60°C	NBR (nitrile)

MATERIALS IN CONTACT WITH FLUID

(*) Ensure that the compatibility of the fluids in contact with the materials is verified

	Brass body	Stainless steel body
Body	Brass	AISI 316 SS
Core tube	Stainless steel	Stainless steel
Core and plugnut	Stainless steel	Stainless steel
Springs	Stainless steel	Stainless steel
Seals	NBR	NBR
Disc and poppets	NBR	NBR
Seat	Brass	Stainless steel

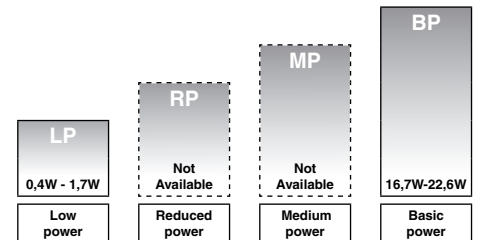
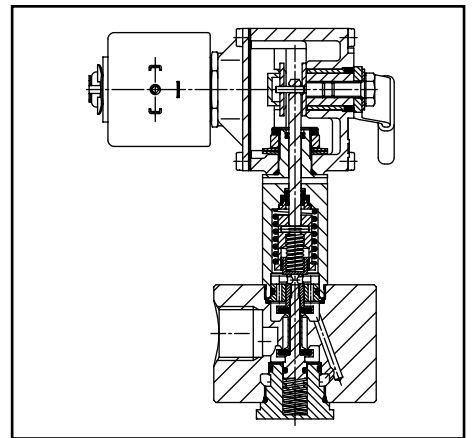

POWER LEVELS - cold electrical holding values (watt)

SPECIFICATIONS

pipe size	orifice size	flow coefficient Kv		operating pressure differential (bar)		power level	prefix optional solenoids						basic catalogue number			
				min.	max. (PS)		NEMA 7&9	ATEX / IECEx				IP65				
								air (*)	Ex d	Ex e mb	Ex mb				Ex ia	EE x nA
Npt	(mm)	(m ³ /h)	(l/min)			~/=	~/=	EF	NF	EM	PV	IS	ZN	SC	brass	stainless st.
3/2 - U - Universal, single solenoid, manual reset (NVR)																
1/4	9,0	0,68	11,3	0,0	10,0	LP	-	-	●	-	○	○	●	●	B307A416	B307A406
1/4	9,0	0,68	11,3	0,0	10,0	BP	●	●	-	-	-	●	●	●	B307B016	B307B006
3/8	9,0	0,68	11,3	0,0	10,0	LP	-	-	●	-	○	○	●	●	B307A446	B307A436
3/8	9,0	0,68	11,3	0,0	10,0	BP	●	●	-	-	-	●	●	●	B307B046	B307B036
1/2	9,0	0,68	11,3	0,0	10,0	LP	-	-	●	-	○	○	●	●	B307A476	B307A466
1/2	9,0	0,68	11,3	0,0	10,0	BP	●	●	-	-	-	●	●	●	B307B076	B307B066

● Available feature ○ Available feature in DC only - Not available

PREFIX TABLE

prefix							description	power level			
1	2	3	4	5	6	7		LP	RP	MP	BP
S	C			D	U		Dustproof (EN 50281-1-1)*	●	-	-	●
E	F						Explosionproof - NEMA 7, 9 - Zinc plated steel conduit	-	-	-	☆
E	V						Explosionproof - NEMA 7, 9 - 316 SS conduit	-	-	-	☆
E	M						Waterproof IP67 - Metal enclosure (EN/IEC 60079-7+18, 61241-1)*	●	-	-	-
		E	T				Threaded conduit/hole (M20 x 1,5)	●	-	-	●
I	S						Intrinsically safe with SC coil (EN/IEC 60079-11+26, 61241-11)*	○	-	-	-
N	F						Flameproof - Aluminium (EN/IEC 60079-1, 61241-1)*	-	-	-	●
P	V						Encapsulated epoxy moulded (EN/IEC 60079-18, 61241-18)*	-	-	-	-
S	C						Solenoid with spade plug connector (EN/IEC 60730)	●	-	-	●
W	P						Waterproof IP67 - Metal enclosure	●	-	-	●
W	P			D	U		Waterproof IP67 - Metal enclosure, Dustproof (EN 50281-1-1)*	●	-	-	●
W	P			I	S		I.S. with Metal IP67 enclosure (EN/IEC 60079-11+26, 61241-11)*	○	-	-	-
W	P			Z	N		Waterproof IP67 - Metal enclosure (EN 50021, 50281-1-1)*	-	-	-	-
W	S						Waterproof IP67 - 316 SS enclosure	●	-	-	●
W	S			D	U		Waterproof IP67 - 316 SS enclosure, Dustproof (EN 50281-1-1)*	●	-	-	●
W	S	E	M				Waterproof IP67 - 316 SS enclosure (EN/IEC 60079-7+18, 61241-1)*	●	-	-	-
W	S			I	S		I.S. with 316 SS IP67 enclosure (EN/IEC 60079-11+26, 61241-11)*	○	-	-	-
W	S	N	F				Flameproof - 316 SS (EN/IEC 60079-1, 61241-1)*	-	-	-	●
W	S	Z	N				Waterproof IP67 - 316 SS enclosure (EN 50021, 50281-1-1)*	-	-	-	-
						T	Threaded conduit (1/2" NPT)	-	-	-	●
						H	Class H - Battery charging circuit	-	-	-	●
						H	Class H - High temperature	-	-	-	●
Z	N					X	Moulded enclosure (EN 50021, 50281-1-1)*	○	-	-	●
							Other special constructions	●	-	-	●

PRODUCT SELECTION GUIDE

STEP 1

Select basic catalogue number, including pipe thread identification letter. Refer to the specifications table on page 1 or 2.
Example: B307B016

STEP 2

Select prefix (combination). Refer to the specifications table on page 1 and the prefix table on page 2, respect the indicated power level.
Example: EMET

STEP 3

Select suffix (combination) if required. Refer to the suffix table on page 2, respect the indicated power level.
Example: V

STEP 4

Select voltage. Refer to standard voltages on page 3.
Example: 230V / 50Hz

STEP 5

Final catalogue / ordering number.
Example: EMET B307B016 V 230V / 50 Hz

SUFFIX TABLE

suffix					description	power level			
1	2	3	4	5		LP	RP	MP	BP
E					EPDM (ethylene-propylene)	-	-	-	-
J					CR (chloroprene)	-	-	-	-
N					Oxygen service (CR (chloroprene))	-	-	-	-
N	V				FPM (fluoroelastomer) and parts cleaned for oxygen service	●	-	-	●
V					FPM (fluoroelastomer)	●	-	-	●
	C	O			Epoxy coating on all external surfaces	●	-	-	●
	M	B			Mounting bracket	●	-	-	●
		P			Dry gas, non-lubricated air construction	-	-	-	-
		Q			Long life, quiet operation construction	-	-	-	-
			M	O	Push type manual operator	-	-	-	-
			M	S	Screw type manual operator	-	-	-	-
				M	Metering device	-	-	-	-

- Available feature
- Available feature in DC only
- ☆ Available feature in AC only
- Not available
- * ATEX solenoids are also approved according to EN 13463-1 (non electrical valves)

OPTIONS & ACCESSORIES

catalogue number	spare parts kit no. ⁽¹⁾		mounting bracket no.
	~	=	
SC B 307B006	C115468	C115472	115292-001
SC B 307B016	C115469	C115473	115292-001
SC B 307B036	C115468	C115472	115292-001
SC B 307B046	C115469	C115473	115292-001
SC B 307B066	C115468	C115472	115292-001
SC B 307B076	C115469	C115473	115292-001
SC B 307A406	C132660	C132660	115292-001
SC B 307A416	C132661	C132661	115292-001
SC B 307A436	C132660	C132660	115292-001
SC B 307A446	C132661	C132661	115292-001
SC B 307A466	C132660	C132660	115292-001
SC B 307A476	C132661	C132661	115292-001

⁽¹⁾ Standard prefixes/suffixes are also applicable to kits

ORDERING EXAMPLES VALVES:

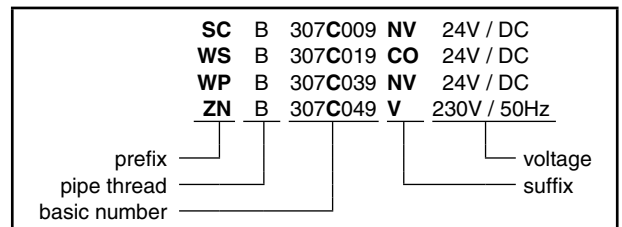

ORDERING EXAMPLES KITS:

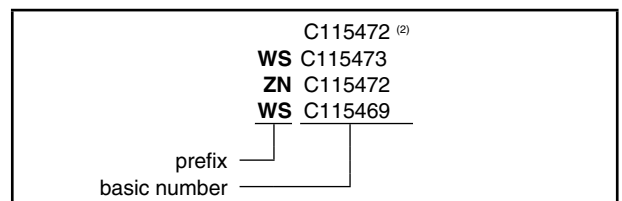

⁽²⁾ Basic kit number applies to SC coil construction

EXPLANATION OF TEMPERATURE RANGES OF SOLENOID VALVES

Valve temperature range	The valve temperature range (TS) is determined by the selected seal material, the temperature range for proper operation of the valve and sometimes by the fluid (e.g. steam)
Operator ambient temperature range	The operator ambient temperature range is determined by the selected power level and the safety code
Total temperature range	The temperature range of the complete solenoid valve is determined by the limitations of both temperature ranges above

ELECTRICAL CHARACTERISTICS

Coil insulation class	F
Connector	Spade plug
Connector specification	ISO 4400 (cable Ø 6-10 mm)
Electrical safety	IEC 335
Standard voltages:	DC (=) 24V - 48V AC (~) 24V - 48V - 115V - 230V/50 Hz; Other voltages are available on request

prefix option	power ratings				operator ambient temperature range (TS) (C°) ⁽¹⁾	safety code	electrical enclosure protection (EN 60529)	replacement coil / kit		type ⁽²⁾
	inrush	holding		hot/cold				~	=	
	(VA)	(VA)	(W)	(W)				230V/50 Hz	24V/DC	
Basic power (BP)										
SC	78	35	16,7	13,5/19,7	-40 to +75	EN 60730	IP65, moulded	400-425-217	400-425-342	01
WP/WS	78	35	16,7	13,5/19,7	-40 to +75	EN 60730	IP67, steel/SS	400-405-217	400-405-342	02
NF/WSNF	78	35	16,7	13,5/19,7	-60 to +60	II2G Ex d IIC T4, II2D Ex tD	IP67, alu./SS	400-405-217	400-405-342	-
EF/EV	70	40	17,1	15,8/22,6	-40 to +52/40	NEMA type 7 and 9	4X, moulded	238-614-159D	274-714-106D	03
ZN	78	35	16,7	13,5/19,7	-20 to +50	II3GD EEx nA II T3	IP65, moulded	-(³)	-(³)	01
Low Power (LP)										
SC	1,2	1,2	1,2	1,3/1,3	-40 to +75	EN 60730	IP65, moulded	400-929-097	400-929-042	04
WP/WS	1,2	1,2	1,2	1,3/1,3	-40 to +75	EN 60730	IP67, steel/SS	400-930-097	400-930-042	05
EM/WSEM	1,2	1,2	1,2	1,3/1,3	-40 to +60	II2G Ex e mb II T6, II2D Ex tD A21	IP67, steel/SS	400-930-097	400-930-042	05
ISSC	-	-	-	0,4/0,4	-40 to +60	II1G Ex ia IIC T6, II2D Ex iaD 21	IP65, moulded	-	123-256-001	04
WPIS/WSIS	-	-	-	0,4/0,4	-40 to +60	II1G Ex ia IIC T6, II2D Ex iaD 21	IP67, steel/SS	-	109-496-003	05
ZN	-	-	-	1,7/1,7	-20 to +50	II3GD EEx nA II T3	IP65, moulded	-	-(³)	04

⁽¹⁾ Temperature range can be limited by sealings

⁽³⁾ Multiple coil kits are available under ATEX/IECEx, contact us

⁽²⁾ Refer to the dimensional drawings on page 4

- Not available

ADDITIONAL OPTIONS

- Other pipe threads are available on request
- Compliance with "UL", "CSA" and other local approvals available on request
- 1/2" NPT (prefix "T") and M20 x 1,5 (prefix "ET") conduits (aluminium or 316 SS) available for steel solenoid housing
- Special moulded-in solid state components for peak voltage suppression and/or rectification (four diode bridge)

INSTALLATION

- The solenoid valves have to be mounted vertically and in an upright position for best performance
- Multi language installation/maintenance instructions are included with each valve
- Threaded pipe connection identifier is B = NPT (ANSI 1.20.3)
- Other pipe threads are available on request
- Ex e mb (prefix "EM") execution: solenoid enclosure has a cable gland with integral strain relief for cables with an o.d. from 7 to 12 mm and is provided with an internal and external connection facility for an earthing or bonding conductor

DIMENSIONS (mm), WEIGHT (kg)



TYPE 01:
Epoxy moulded
SC: IEC 335 / ISO 4400
ZN: EN 50021, 50281-1-1

307B006 / B016 / B036 / B046 / B066 / B076

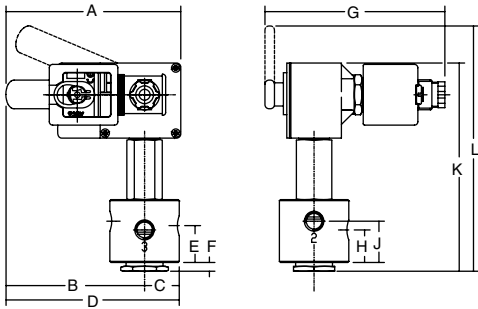

TYPE 02:
Metal, epoxy coated / AISI 316 SS
WP / WS: IEC 335

307B006 / B016 / B036 / B046 / B066 / B076

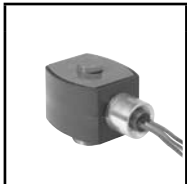
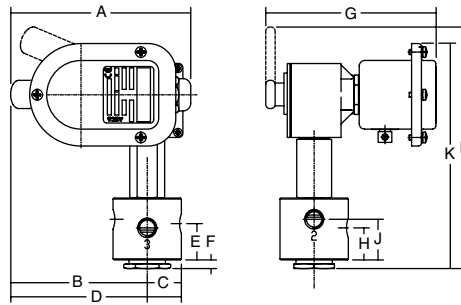

TYPE 03:
Epoxy encapsulated
EF and EV: NEMA type 7, 9 / ICS-6 ANSI

307A406 / A416 / A436 / A446 / A466 / A476

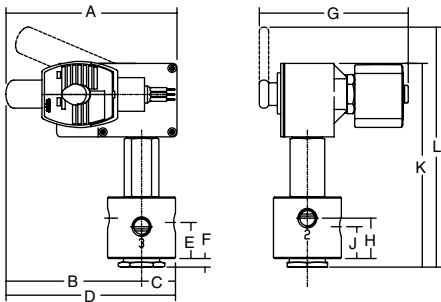

TYPE 04:
Epoxy moulded
SC: IEC 335 / ISO 4400
ZN: EN 50021, 50281-1-1
ISSC: EN/IEC 60079-11+26, 61241-11

307A406 / A416 / A436 / A446 / A466 / A476

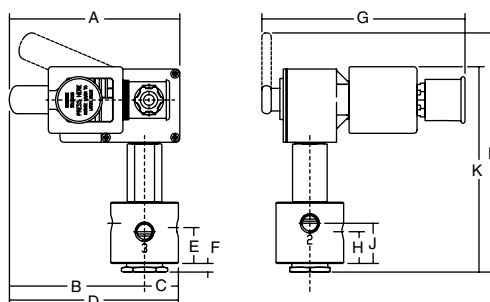

TYPE 05:
Metal, epoxy coated / AISI 316 SS
WP / WS: IEC 335
EM / WSEM: EN/IEC 60079-7+18, 61241-1
WPIS / WSIS: EN/IEC 60079-11+26, 61241-11

307A406 / A416 / A436 / A446 / A466 / A476

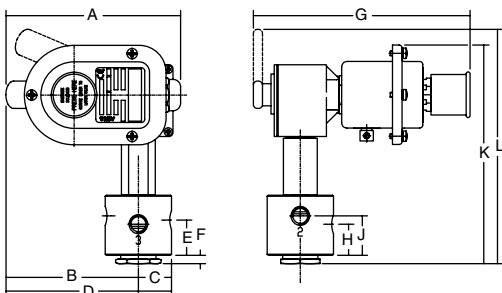

DIMENSIONS (mm), WEIGHT (kg)



type	prefix option	power level	A	B	C	D	E	F	G	H	J	K	L	weight
01	SC, ZN	BP	128	102	25	127	27	6	132	24	30	152	180	2,5 kg
02	WP, WS	BP	134	102	25	127	27	6	130	24	30	168	180	2,5 kg
03	EF, EV	BP	128	102	25	127	27	6	167	24	30	152	180	2,5 kg
04	SC, ZN, ISSC	LP	134	102	25	127	27	6	153	24	30	154	180	2,5 kg
05	WP, WS, EM, WSEM, WPIS, WSIS	LP	134	102	25	127	27	6	167	24	30	168	180	2,5 kg

MOUNTING BRACKETS

