



OPERATORS

for potentially explosive atmospheres
flameproof enclosure,
II 2 G/D Ex d IIC Gb T6..T4 / Ex t IIIC Db IP67
aluminium, stainless steel

Series

NF
WSNF

FEATURES

- Explosion proof operator, intended for use in potentially explosive atmospheres, according to Directive ATEX 94/9/EC
- EC type examination certificate (LCIE 00 ATEX 6008 X) and IECEx certificate (IECEx LCI 07.0015X) are in compliance with the European Standards EN-IEC 60079-0, EN-IEC 60079-1 and EN-IEC 61241-1
- Easy electrical installation by means of a screw terminal coil
- Enclosure provided with a 1/2 NPT or M20 x 1,5 threaded entry hole for a broad range of cable glands
- Ingress protection degree IP67
- The operator is available as both a push or pull type solenoid and can be supplied on a wide range of valves with ASCO interface

CONSTRUCTION

Solenoid enclosure	NF	Chromated aluminium, epoxy coated
	WSNF	Stainless steel (AISI 316 L SS)
Bonnet	NF	Steel (zinc plated)
	WSNF	Stainless steel (nickel plated)
Core, tube, springs & plugnut	all	Stainless steel
Shading coil	all	Copper or silver
Nameplate	NF	Stainless steel
	WSNF	Stainless steel
Coil connection	all	Embedded screws terminals
Fasteners & screws	all	Stainless steel

ELECTRICAL CHARACTERISTICS

Standard voltages:
DC (=): 24V - 48V
AC (-): 24V - 48V - 115V - 230V / 50 Hz
(Other voltages and 60 Hz on request)

SAFETY CODE

II 2G Ex d IIC Gb T6..T4 (gas)
II 2D Ex t IIIC Db IP67 85°C to 135°C (dust)

TEMPERATURE CLASSIFICATION TABLES

The minimum allowable ambient temperature is -60°C for the operator.
Select the requested "T" classification from the temperature classification tables (AC or DC), respecting the maximum ambient temperature and cold (20°C) electrical holding power values.

AC (-) Solenoids

power level (watt)	insulation class	maximum ambient ⁽¹⁾ temp. "T" classification		
		T6 (G) 85°C (D)	T5 (G) 100°C (D)	T4 (G) 135°C (D)
Low power (LP)				
1,85 ⁽²⁾	F/H	75°C	80°C	-
Reduced power (RP)				
3,7 ⁽²⁾	F/H	60°C	75°C	100°C
Medium power (MP)				
5,8 ⁽²⁾	F/H	60°C	75°C	100°C
Basic power (BP)				
10,0 ⁽²⁾	F/H	40°C	60°C	75°C
10,0 ⁽²⁾	F/H	40°C	60°C	100°C
10,5	F/H	25°C	40°C	60°C
10,5	F/H	25°C	40°C	75°C
13,4 ⁽²⁾	F/H	40°C	60°C	75°C
14,1 ⁽²⁾	F/H	40°C	60°C	90°C
15,4	F/H	25°C	40°C	60°C
15,4	F/H	25°C	40°C	75°C
16,5	F/H	40°C	60°C	75°C
16,7	F/H	-	25°C	40°C
16,7	F/H	-	25°C	60°C
20,0	F/H	-	25°C	40°C
20,0	F/H	-	25°C	60°C
20,5	F/H	-	-	25°C
28,0	F/H	-	-	25°C

DC (=) Solenoids

power level (watt)	insulation class	maximum ambient ⁽¹⁾ temp. "T" classification		
		T6 (G) 85°C (D)	T5 (G) 100°C (D)	T4 (G) 135°C (D)
Low power (LP)				
1,8	F/H	75°C	80°C	-
Reduced power (RP)				
3,6	F/H	60°C	75°C	100°C
Medium power (MP)				
5,7	F/H	60°C	75°C	100°C
Basic power (BP)				
10,0	F/H	40°C	60°C	100°C
11,2	F/H	40°C	60°C	75°C
11,2	F/H	40°C	60°C	100°C
14,0	F/H	40°C	60°C	90°C
16,8	F/H	40°C	60°C	75°C
16,8	F/H	40°C	60°C	100°C
17,4	F/H	25°C	40°C	60°C
19,7	F/H	25°C	40°C	60°C
19,7	F/H	40°C	60°C	75°C
23,0	F/H	25°C	40°C	60°C
23,0	F/H	25°C	40°C	75°C
26,6	F/H	25°C	40°C	60°C
29,5	F/H	-	25°C	40°C
36,2	F/H	-	25°C	40°C

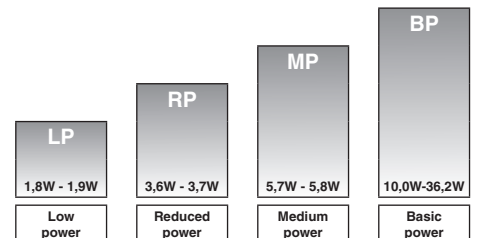
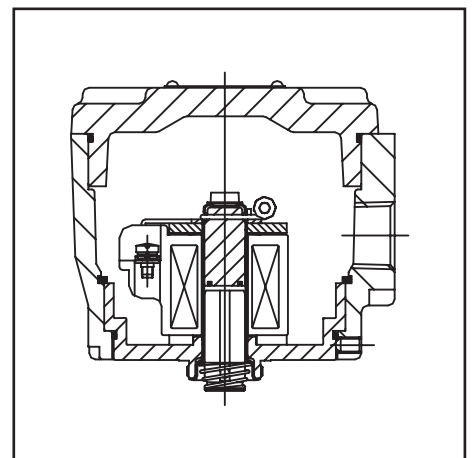

POWER LEVELS - cold electrical holding values (watt)

⁽¹⁾ Make sure that the selected ambient temperature does not exceed the allowable valve temperature characteristics as specified on the appropriate valve catalogue sheets.

⁽²⁾ AC (-) rectified coil construction

PREFIX TABLE

prefix							description	power level			
1	2	3	4	5	6	7		LP	RP	MP	BP
N	F	E	T				Threaded conduit/hole (M20 x 1,5)	●	●	●	●
W	S	N	F				Flameproof - Aluminium (EN/IEC 60079-1, 61241-1)*	●	●	●	●
				H	C		Flameproof - 316 SS (EN/IEC 60079-1, 61241-1)*	●	●	●	●
				H	T		Class H - Battery charging circuit	●	●	●	●
				H	T	X	Class H - High temperature	●	●	●	●
							Other special constructions	●	●	●	●

● Available feature

* ATEX solenoids are also approved according to EN 13463-1 (non electrical valves)

ORDERING EXAMPLES VALVES:

NF	8	327B001	230V / 50/60 Hz
NFET	G	327B001 V	230V / 50/60 Hz
NFETHC	B	320A192 MO	24V / DC
WSNF	B	320A184 E	24V / DC
NFHT	B	316A054 V	230V / 50 Hz
WSNFHT	B	316B076	CO240V / 60 Hz

prefix ——— voltage
 pipe thread ——— suffix
 basic number ———

MOUNTING BRACKET

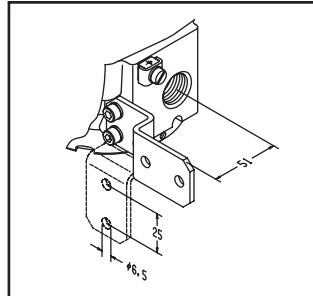

Bracket kit no.: C139824
 contains: **Stainless steel**
304 SS screws and bracket

PRODUCT SELECTION GUIDE

(The selection can only be made in conjunction with the appropriate valve catalogue sheet)

STEP 1

Select basic valve catalogue number, including pipe thread identification letter from one of the specification tables on the separate catalogue pages.

Example: 8327B002

STEP 2

Select voltage. Refer to standard voltages on page 1.

Example: 230V / 50/60Hz

STEP 3

Select solenoid prefix (combination). Refer to the prefix table on this page and respect the indicated power level, cold electrical holding values and "T" classification mentioned on page 1.

NOTE: Make sure that the ambient temperature does not exceed the allowable valve temperature characteristics.

Example: WSNF

60°C ambient

Basic Power (BP) 10W

II 2G Ex d IIC Gb T5

II 2D Ex t IIC Db IP67 T100°C

STEP 4

Final catalogue / ordering number.

Example:

WSNF 8327B002 230V / 50/60 Hz

ADDITIONAL OPTIONS

- Special moulded-in solid state components for peak voltage suppression and/or AC (~) rectification
- Cable glands (Flameproof cable entry devices for cable 8,5-16 mm or 9-12 mm) refer to section 14

INSTALLATION

- Multi language installation/maintenance instructions are included with each valve
- The solenoid operators can be mounted in any position without affecting operation
- Any Ex d IIC approved cable entry device can be fitted in the 1/2" NPT (M20 x 1,5 as an option) threaded entry hole, refer to the nameplate for identification of the maximum cable temperature
- Internal and external earthing connection
- The operator can be rotated 360° to select the most favourable position for cable entry

DIMENSIONS (mm), WEIGHT (kg)

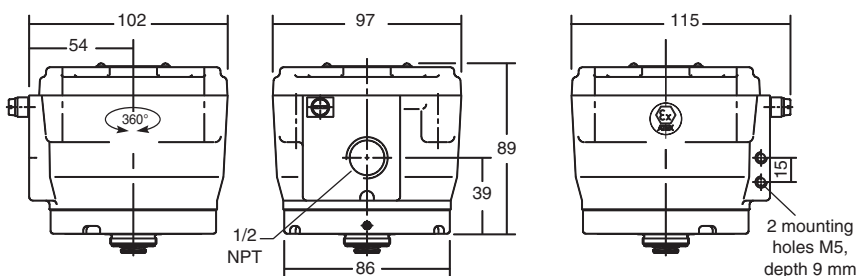

prefix	weight
NF	1,4 kg
WSNF	2,7 kg