

Maxseal Solenoid Operated Valves



ICO4S
1/4" 3/2
207B
PBMR



Typical Applications

- 1/4" 3/2 PUSH BUTTON MANUAL RESET
- Actuator Control
- Direct Acting Shut Off Valve
- Oil & Gas Applications
- Turbine Fuel Control

Thompson Valves Ltd

Description

- Model: ICO4S 1/4" 3/2 Uni Direct Acting Solenoid Valve
- High Pressure
- Max Inlet Pressure 207 bar (3000 psi)
- Reliable and long life, ideal for a one time installation
- Control of pneumatic or hydraulic operated equipment

<input type="checkbox"/> Standard Features	<input type="checkbox"/> ICO4S 1/4" 3/2 207B PBMR
<input type="checkbox"/> Solenoid Materials of Construction	<input type="checkbox"/> Solenoid Pot - Stainless Steel - BFC 316 <input type="checkbox"/> Top Cover - Stainless Steel- BFC 316 <input type="checkbox"/> Valve Body & Trim Materials - 316 Stainless Steel <input type="checkbox"/> O-Rings Seals - High Nitrile (NBR) <input type="checkbox"/> Seats - Nylon 66 <input type="checkbox"/> Coil Insulation - Class H
<input type="checkbox"/> Maximum Inlet Pressure	<input type="checkbox"/> 207 Bar (3000 PSI)
<input type="checkbox"/> Flow Rates	<input type="checkbox"/> $C_v = 0.28$ USgpm for 1 psi Δp <input type="checkbox"/> $K_v = 4.03$ l/min for 1 bar Δp
<input type="checkbox"/> Temperature Ratings	<input type="checkbox"/> Media (Min/Max -20°C/90°C) - Ambient (Min/Max 0°C/60°C)
<input type="checkbox"/> Valve Size	<input type="checkbox"/> 1/4" Poppet Valve
<input type="checkbox"/> Process Connections	<input type="checkbox"/> 1/4" NPT
<input type="checkbox"/> Conduit Connection	<input type="checkbox"/> M20 x 1.5 Conduit Thread
<input type="checkbox"/> Media	<input type="checkbox"/> Liquid & Gases
<input type="checkbox"/> Weight	<input type="checkbox"/> 5.5 Kg

<input type="checkbox"/> Recommended Spares Kits		
<input type="checkbox"/> Soft Spares (O-rings, Springs etc)	<input type="checkbox"/> Standard & Extreme Service <input type="checkbox"/> Low Temperature valves	Y163A010000-SS See Valve Data Sheet
<input type="checkbox"/> Spare Coil Assembly	<input type="checkbox"/> Standard 24V DC (4.5 Watts) <input type="checkbox"/> Other Variations	Y163P0101B0 See Valve Data Sheet

<input type="checkbox"/> Options	
<input type="checkbox"/> High Temperature Options	<input type="checkbox"/> High Temperature Spacer (Max Med/Amb 120°C/60°C) Please Call for Dimensions
<input type="checkbox"/> Process Connections	<input type="checkbox"/> Thread - 1/4" BSPP
<input type="checkbox"/> Conduit Connection	<input type="checkbox"/> 1/2" NPT
<input type="checkbox"/> Product lead time	<input type="checkbox"/> Y163PA1J1BS - 1 WEEK (SUBJECT TO QUANTITIES) <input type="checkbox"/> Other Variations - Please call for possible delivery dates

Technical Specification

Pressures

Test (Proof) Pressure	<input type="checkbox"/> 310 bar (4500 PSI)
Maximum Inlet Pressure	<input type="checkbox"/> 207 Bar (3000 PSI)
ATEX Clasification	<input type="checkbox"/> Complies with ATEX Directive 94/9/EC
ATEX Certificate	<input type="checkbox"/> SIRA 00ATEX1147
Certification 	<input type="checkbox"/> II 2G
	<input type="checkbox"/> EExd IIC T6 (T _a = -60°C to + 48°C) or
	<input type="checkbox"/> EExd IIC T4 (T _a = -60°C to + 90°C)
IECEX	<input type="checkbox"/> IECEX BAS 04.0019
	<input type="checkbox"/> EExd IIC T6 (T _a = -40°C to + 60°C) or
	<input type="checkbox"/> EExd IIC T4 (T _a = -40°C to + 90°C)
GOST 'K'	<input type="checkbox"/> EExd IIC T6 (T _a = -40°C to + 60°C)
GOST 'R'	<input type="checkbox"/> EExd IIC T6 (T _a = -40°C to + 60°C)
Safety Integrity Level	<input type="checkbox"/> Suitable for SIL 3 Application in Simplex Mode
	<input type="checkbox"/> Suitable for SIL 4 Application in Duplex Mode
Ingress Protection	<input type="checkbox"/> IP66/X8, NEMA 4X
Voltage Surge Protection	<input type="checkbox"/> Surge Suppression Diodes
Coil Insulation	<input type="checkbox"/> Class H
Performance	
Pull-in Voltage	<input type="checkbox"/> 87.5% of Nominal
Response Times	<input type="checkbox"/> Pull-In <150ms
	<input type="checkbox"/> Drop-Out <80ms
Electromagnetic Compability (EMC)	<input type="checkbox"/> EN50081-2/82-1

Valve Symbol

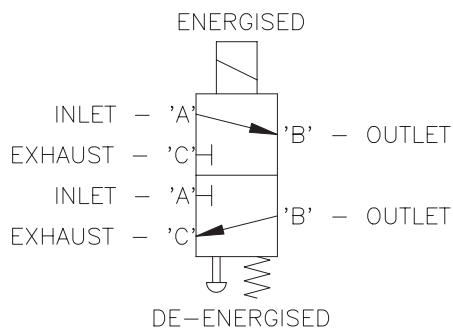

VALVE SYMBOL FOR
ENERGISE TO OPEN
(DE-ENERGISED TO CLOSE)
(NORMALLY CLOSED)

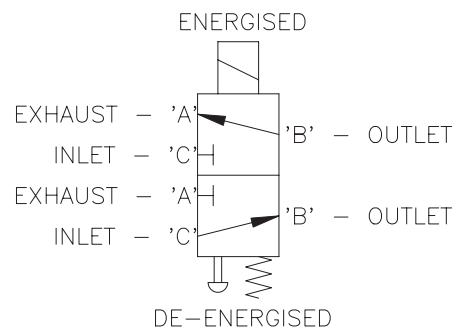

VALVE SYMBOL FOR
ENERGISE TO CLOSE
(DE-ENERGISED TO OPEN)
(NORMALLY OPEN)

Ordering Information

Model	Operating Pressure	Port Config.	Operation	Process Connection	Seat/Seal Materials	Conduit Connection	Voltage	Body/Trim Materials
Y1	6	3	P	A1	J	1	B	S
ICO4S	0-207 Barg (3000 psi)	3/2 UNIVERSAL	PUSH BUTTON MANUAL	A1 1/4" NPT	J Nylon / High Nitrile	1 M20x1.5	A 18/33V DC	S 316 SS / 316 SS
							B 24V DC	
							C 50V DC	
							D 110V DC	
							E 125V DC	
							G 25V AC	
							J 110V AC	
M 240V AC								
E1 1/4" BSPP	K Nylon / Viton®	2 1/2" NPT						

Ordering Example

Y1	6	3	P	A1	K	2	C	S
ICO4S	0-207 Barg (3000 psi)	3/2 UNI	PBMR	1/4" NPT	Nylon / Viton®	1/2" NPT	50V DC	316 SS / 316 SS

Power Consumption (At Nominal)

DC Standard		AC Standard	
18 / 33V DC (24V DC)	7.7 W	25V AC	7.7 W
24V DC	4.5 W	110V AC	9.5 W
50V DC	5.5 W	240V AC	9.3 W
110V DC	9.5 W		
125V DC	7.8 W		

Profile and Dimensions mm

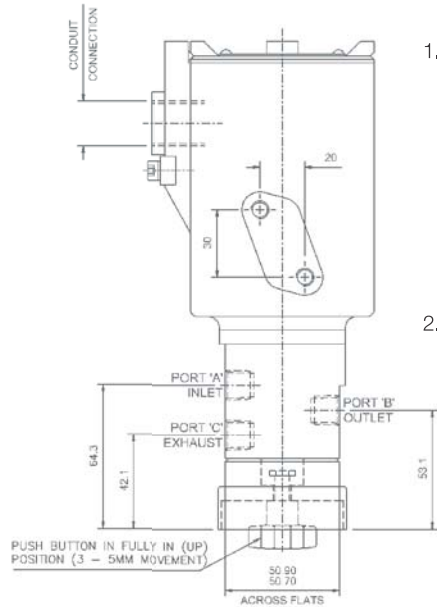
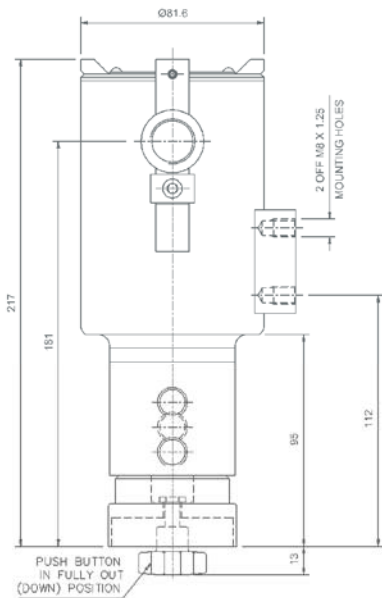

- Valve is energised
Valve does not move
Flow occurs between ports 'B' & 'C'

Push button is pushed upwards
Valve 'changes over'
Flow occurs between ports 'A' & 'B'
- Valve is de-energised
Valve resets
Flow occurs between ports 'B' & 'C'

Thompson Valves reserves the right to amend product specifications or designs without notice. Information is given in good faith and no liability can be accepted for error or omission. Viton® is a registered trademark of DuPont Performance Elastomers.

Thompson Valves, 17 Balena Close, Creekmoor, Poole, Dorset BH17 7EF, ENGLAND
Tel +44 (0)1202 647331 Fax +44 (0)1202 647302 Email maxseal@thompson-valves.com
www.thompson-valves.com A fluid controls business of IMI plc